

PSB heating cable + Connection system + Junction box

Description

The BARTEC PSB system enables you to meet many of the different requirements for electric trace heating systems regarding

- Frost protection
- Temperature maintenance
- Space heating
- Combination of temperature raising and temperature maintenance

It is easier than ever to adapt the heating circuit to the given ambient conditions thanks to the possibility of cutting the heating tape to length and terminating right there and then. The length of the heating circuit can be modified at any time – no matter how the circuit was originally planned. The specific power output per unit length remains unaffected.

Different performance levels allow the easy adjustment to heat losses. The parallel circuit configuration of the heating tape favours its installation on pipes and vessels. Only one single cable is usually put in a straight line, a return path is not necessary. Contrary to constant wattage heating cables, this system allows overlapping of the heating cables which sometimes occurs on valves, fittings, pumps and flanges without causing any damage or risk of overheating. By choosing the adequate protective outer jacket the heating system can adjust to the prevailing ambient conditions. Its robust structure allows its use under even extreme conditions.

Together with the corresponding connection system, the PSB system has been certified for use in hazardous areas. A temperature limiter is not generally necessary, nor does the heating circuit need the approval of an authorised expert.

System overview

- **Self limiting parallel heating cable PSB**
- **Connection systems**
 - TWISTO-B for non-explosive atmospheres
 - PLEXO for hazardous areas
 - Heat shrink technology for Ex and Non-Ex areas
- **Automatic controller**
in mechanical or electronic version
- **Accessories**
such as adhesive tapes, fixing brackets with mounting plates, insulation entries, caution labels

Features

- Easy planning of heating circuits
- Can be used in explosive atmospheres thanks to its innovative connection system
- No need to be approved by authorised inspectors
- Offers a complete range of products
- Simple installation on site

PSB heating circuit in an Ex-area, system PLEXO (typical example)

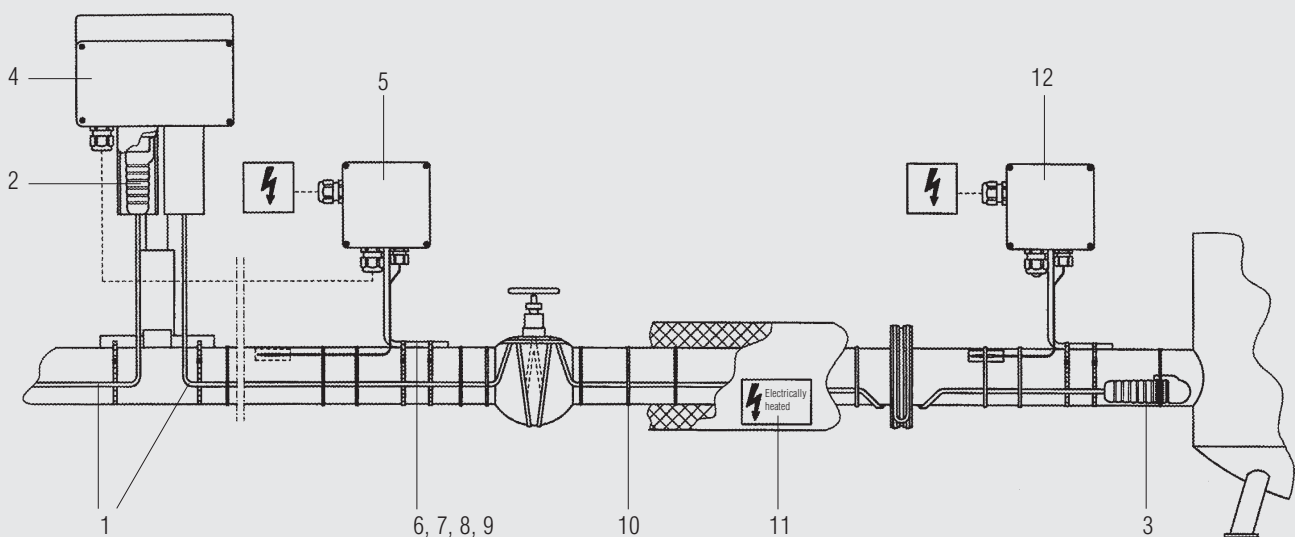

- | | | |
|--|-------------------------------------|---|
| 1 Parallel circuit PSB heating cable | 5 BSTW thermostat | 9 Buckles for fixing strap |
| 2 PLEXO bulkhead plug and socket enclosure termination | 6 Mounting bracket | 10 Self adhesive glass fibre fixing tape |
| 3 PLEXO remote end termination | 7 Mounting plate | 11 "Electrically Heated" caution label |
| 4 EEx e terminal box | 8 Fixing strap for mounting bracket | 12 BSTW thermostat as an extra alarm (optional) |

למידע נוסף



0732001311



www.ateka.co.il



אפקון
מקבוצת
שלמה

אטקה